



# platinum



The ultimate solution for power and data distribution to touch-down desking and conference tables, where ease of access to utilities is paramount.

Platinum is easily installed into new furniture or retro fitted and may be specified with the full range of data, telecom, audio/visual and power sockets. Integral fuses allow compliance to BS6396:2008 where relevant.

Platinum allows total flexibility to meet the demands of any power and data requirement. Easy to use, Platinum allows essential utility connections to be accessed from both sides of the unit without encroaching on the workspace.

The unit can be closed when most connections (including transformer plugs) have been made, to retain a flat work surface.

Finished in silver and grey as standard. Other finishes available subject to order quantity.



## office electrics

1 Calder Point, Monckton Road Industrial Estate,  
Wakefield, West Yorkshire, WF2 7AL  
Tel: +44 (0) 1924 367255 Fax: +44 (0) 1924 290652  
Email: sales@office-electrics.co.uk www.office-electrics.com

Elsafe, Unit 1, 17 Rodborough Road,  
Frenchs Forest NSW 2086, Australia  
Tel: +61 2 9454 7500 Fax: +61 2 9454 7505  
Email: sales@elsafe.com.au www.elsafe.com.au

## Common Modular Components\*

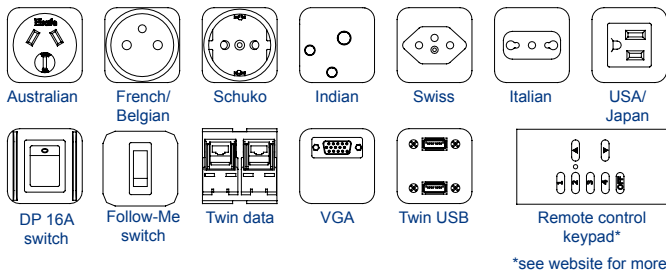

## Standard Unit Lengths

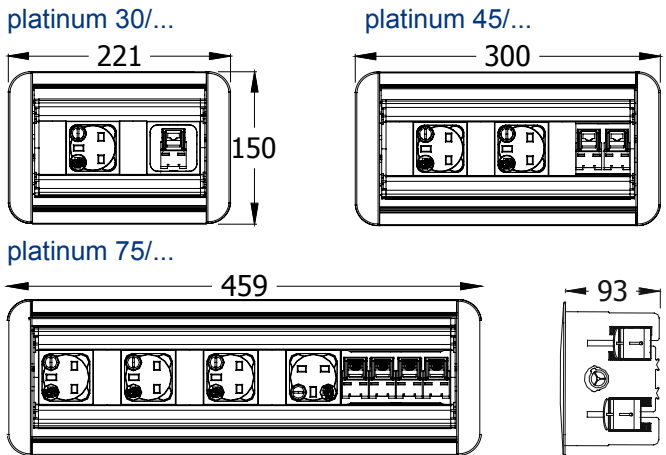

## PLATINUM installation

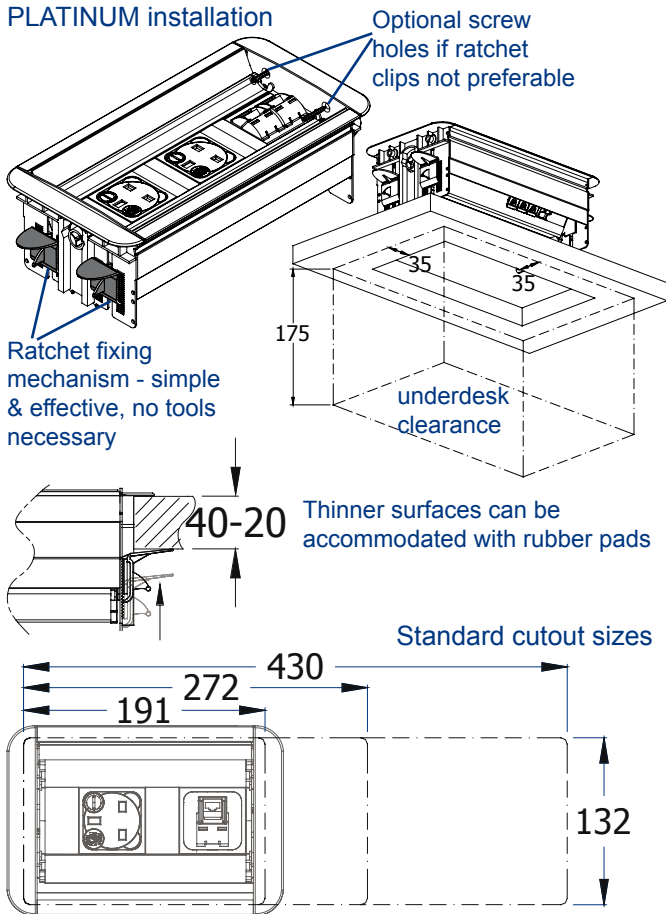

## Features

### Configuration:

Power only / Data only / Combined (Power & Data/AV)  
 Internal segregation between Power and Data/AV in combined PLATINUM units

**Earthing:** Fully earthed aluminium construction - **both body AND frame** - as required by BS6396

### Earth Bonding:

Earth bonding slots along length of the unit allow the attachment of earth bonding lead with standard 3mm ring terminal. Earth bonding kit is sent as standard with every Platinum

### Fusing:

(to enable compliance to BS6396)  
 5 x 20mm anti-surge ceramic fuses, with colour-coded fuseclips to denote the rating (3.15A/5A)

### Security:

ANTI-FLEX system: Unique full length locking system guarantees unit integrity regardless of length

### Testing:

100% testing - continuity, polarity, insulation & earth

### Soft Wiring (power)

Power hardwired to Wieland ST/GST connector allows starter cables to be changed to suit requirements, especially during moves and changes (CHURN)

### Soft Wired Data

As well as soft-wired power, PLATINUM can accommodate soft wired data. Using our inline couplers, data cables can be changed "on-site" to accommodate changes in length often associated with churn

### Protection:

Power cleaner, surge protector, MCB, RCD, RCBO, etc.

### Conferencing features:

#### Active Room Control

PLATINUM can also be fitted with room control keypads which, when used in conjunction with our in-line room controllers, allow the user to control various functions around the room (eg: blinds, shutters, projection screen and lighting) directly from the PLATINUM

#### Follow-me switch

Integration with industry standard VGA switchers to allow intelligent control of AV facilities by multiple delegates

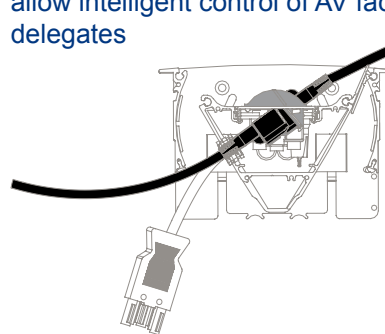

Angled data fascias allow data cabling to pass straight through PLATINUM, ensuring the integrity of cables which have a minimum bend radii (CAT5e, CAT6, etc)